

ENVIRONMENTAL PRODUCT DECLARATION

In accordance with ČSN ISO 14025:2010
and EN 15804: 2012+A2:2019+AC:2021

Organization	FERT a.s.
Industry Program Operator	CENIA, Czech Environmental Information Agency, Executive Body of NPEZ Agency
Author	Technický a zkušební ústav stavební Praha, s.p.
Declaration No.:	7230001
Publication Date	2023-03-24
Valid until	2028-03-23 in accordance with EN 15804+A2:2019



Reinforcing steel

1. General information declaration

FERT a.s.	Reinforcing steel
Programme: 'National programme of environmental labelling' - CR Industry operator: CENIA, Czech Environmental Information Agency, executive function of the NPEZ Agency, Moskevská 1523/63, Praha 10, 101 00, www.cenia.cz	Manufacturer's name and address: FERT a.s. Petra Bezruče 447/14 392 01 Soběslav - Soběslav II, CZ
EPD registration number: 7230001	Declared unit: 1 t of average product – Reinforcing steel
Product category rules: EN 15804+A2:2019 as basic PCR Date of issue: 2023-03-24 Valid until: 2028-03-23 in accordance with EN 15804+A2:2019	Product: Reinforcing steel

Through this Environmental Product Statement, **FERT a.s.** expresses its position on environmental protection issues and proves that it has adequate data on the environmental impacts caused by the production of its products.

The company FERT a.s. was founded in 1992 and has aimed to use modern and advanced technologies since its establishment. The main production content is the production of cold-formed reinforcing steel and the subsequent machine production of prefabricated reinforcement cages for modern ceiling structures and spacing elements. In this area, the company tries to meet customer requirements as much as possible and come up with new products. We deliver our products to the domestic market and to almost all of Europe. Effective technical control and testing have been an integral part of the company since the very beginning. The company has an integrated quality management system certified in accordance with EN ISO 9001:2016. The products are certified by the following accredited certification institutes TZÚS Praha, TSÚS Bratislava, Prüfstelle für Betonstahl Prof. Dr.–Ing.G.Rehm GmbH, TÜV AUSTRIA TVFA.

FERT a.s uses actively the European Regional Development Fund and, thanks to this, it modernizes its machinery, reduces the energy requirements for production and operations.

With regard to the possibility of comparing products as part of the **life cycle assessment of construction works** based on their EPDs, which is carried out by determining their contribution to the environmental properties of construction works, it is necessary that the EPD of given construction products be prepared in accordance with the requirements of the standard **EN 15804+A2:2019 Sustainability of construction works – Environmental product declarations – Core rules for the product category of construction products**.

1.1. Product Data

The company's management has decided to include the following products in the environmental impact assessment:

- Ribbed reinforcing steel in coils or bars
- Smooth reinforcing steel in coils or bars
- Prefabricated reinforcing cage, type E
- Welded mesh, type P
- Prefabricated steel reinforcement, type D
- Prefabricated steel reinforcement, type S
- Masonry reinforcement, type I

1.1.1. Ribbed reinforcing steel B500A, B550A

Ribbed reinforcing steel B500A, B550A – cold-drawn steel with a yield strength of 500 or 550 MPa, in coils or straightened into bars and cut to size.

The products listed in this technical specification are produced by continuous cold forming (rolling). In the first stage, the wire is freed from scales. In the second stage it is covered with a layer of soap powder. In the third stage the wire is formed and, in the fourth stage, it is wound into coils.



1.1.2. Smooth reinforcing steel B500A-G, B550A-G

Smooth reinforcing steel B500 A-G, B550A-G – cold-drawn steel with a yield strength of 500 or 550 MPa, in coils. The products listed in this technical specification are produced by continuous cold forming (rolling). In the first stage, the wire is freed from scales. In the second stage it is covered with a layer of soap powder. In the third stage the wire is formed and, in the fourth stage, it is wound into coils.



1.1.3. Prefabricated reinforcing cage, type E (example of one product group)

Prefabricated reinforcing lattice cage, type E, is made of reinforcing steel with an upper ribbed or smooth flange, lower ribbed flanges and continuous smooth diagonal bracing connected to the flanges with resistance spot welds spaced approx. 200 mm.

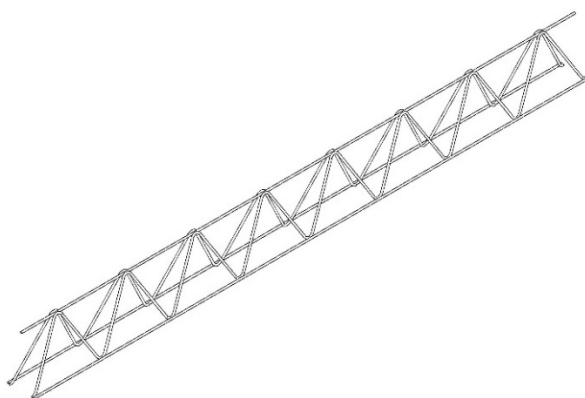

1.1.4. Welded mesh, type P

FERT welded mesh, type P – reinforcement made of ribbed or smooth reinforcing steel with vertical diagonal bracing connected to longitudinal flanges with spot welds. Type P one-sided reinforcements are used as reinforcement for lintels above window and door openings.

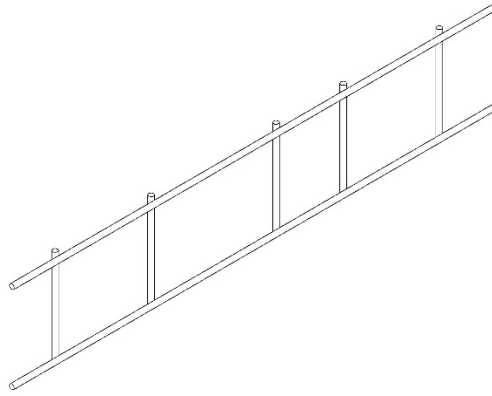

1.1.5. Prefabricated steel reinforcement, type D (example of one product group)

Prefabricated steel reinforcement, type D – a lattice cage made of smooth reinforcing steel and general-purpose wire with spot welds, joined at the joints of the upper and lower flanges with continuous diagonal bracing. Cuts are always made at the contact of the diagonal bracing with the upper flange. The length of the element is usually 2 m.

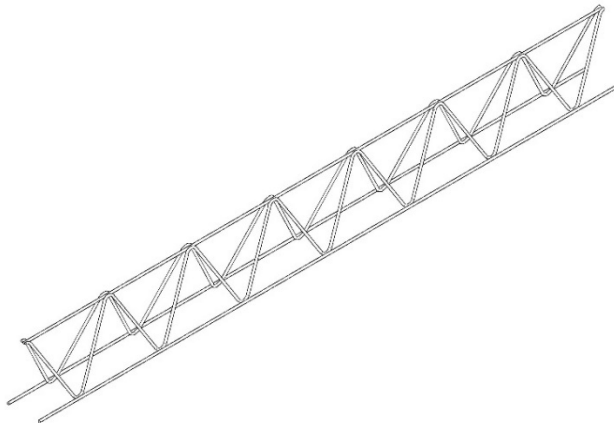

1.1.6. Welded mesh, type S

Prefabricated steel reinforcement, type S – flat mesh, curved 5 times, made of drawn general-purpose wire with spot welds butt-joined at the joints of the upper and lower flanges with continuous diagonal bracing. The length of the element is usually 2 m.

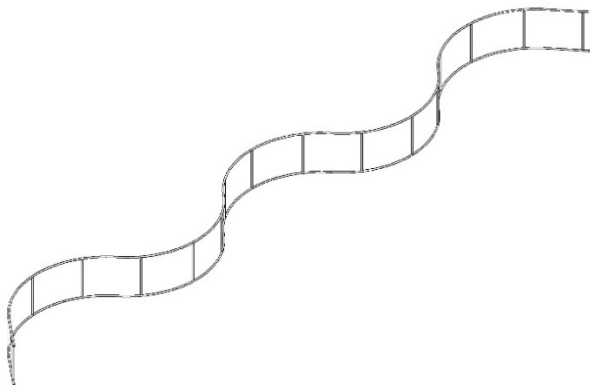

1.1.7. Welded masonry reinforcement, type I

Welded lattice reinforcement made of drawn general-purpose wire with spot welds butt-joined at the joints of the end flanges.

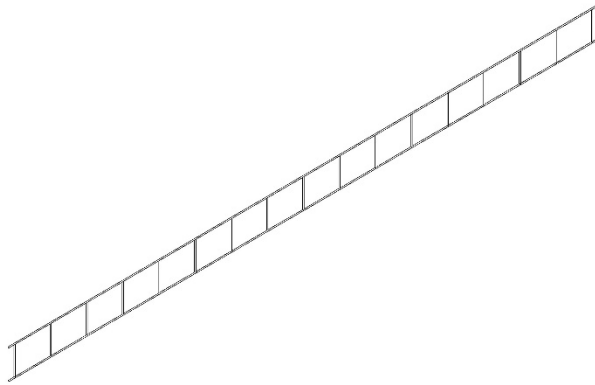

1.1.8. Product technical data

The products are chiefly delivered in accordance with the following standards:

ČSN 42 0139	Steel for the reinforcement of concrete – Weldable ribbed reinforcing steel
ČSN 42 6403	Steel drawn wires with circular cross section. Basic dimensions
ČSN EN 10020	Definition and classification of grades of steel
ČSN EN 10080	Steel for the reinforcement of concrete – Weldable reinforcing steel – General
ČSN EN 10088-3	Stainless steels – Part 3: Technical delivery conditions for semi-finished products, bars, rods, wire, sections and bright products of corrosion resisting steels for general purposes.
ČSN EN ISO 16120-1	Rolled non-alloy steel wire rod for conversion to drawn wire – Part 1: General requirements.
ČSN EN ISO 16120-2	Rolled non-alloy steel wire rod for conversion to drawn wire – Part 2: Specific requirements for general-purpose wire rod
DIN 1045-1:2001-07	Tragwerke aus Beton, Stahlbeton und Spannbeton.
DIN 488	Betonstahl
ISO 6935-2	Steel for reinforcement of concrete
ÖNORM B 4707	Reinforcing steel – Requirements, classification and testing
STO 070-037045	Steel for the reinforcement of concrete – Weldable reinforcing steel, smooth, supplied in circles or straight in bars.

1.1.9. Rules for use

Environment and health during use

Under normal conditions of use, the products do not pose any adverse health effects or release volatile organic compounds into interior air.

Due to the extremely low release of metal from the steel and the low maintenance requirements, no environmental impacts to water, air or soil are expected.

Product certification:

The production is supervised by TZÚS Praha, Prüfstelle für Betonstahl Prof. Dr.–Ing.G.Rehm GmbH, TÜV AUSTRIA TVFA, TSÚS Bratislava.

Reference lifetime

The reference lifetime for the product group is not declared. These are construction products for many different application purposes. The lifetime is limited by the lifetime of the construction works.

Product packaging:

The products are delivered in accordance with the standards listed in Section 1.1.8. The products are delivered in coils (see the figure) or on pallets with wooden dunnage. If necessary, the edges are protected with PVC foil.

1.1.10. Method of delivery

The products are delivered in accordance with the standards listed in Section 1.1.8. The products are delivered in coils (see the figure) or on pallets with wooden dunnage. If necessary, the edges are protected with PVC foil.

Product quality is ensured by an effective quality management system in accordance with EN ISO 9001 and in accordance with the technical regulations regarding the type of product.

1.1.11. Basic raw materials and auxiliary substances

The main raw materials for the production of reinforcing steel include mainly rolled steel wire, purchased reinforcing steel and steel tape are also used in smaller quantities.

The substances listed on the list of substances of very high concern subject to authorization by the European Chemicals Agency are not contained in the Reinforcing Steel product in declarable quantities.

1.1.12. Production

Rolled wire in various diameters is purchased from domestic and foreign steelworks. It is further processed, the mechanical properties are modified by drawing, the diameter is adjusted and the ribbing is pressed, or the wire is left smooth. Subsequently, the smooth and ribbed material is processed on production lines, where it is welded into products according to the required length and height.



1.1.13. Waste management

The waste generated in the production process is collected according to type and registered in accordance with regulations.

The possibility of recycling used products (after the end of their lifetime)

The ability of steel to restore its original properties without any loss of quality after melting makes it the most recycled material in the world.

In the built-up environment, up to 100% of products can be reused or recycled at the end of their lifetime.

1.2. LCA: Calculation rules

1.2.1. Declared unit

The declared unit is 1 t of the average manufactured product – Reinforcing steel

All inputs and outputs of this report were considered as consumption or production related to the production of 1 t of the named product. In the average product, the production of all types of products is considered. In terms of product types, spatial reinforcement products 1.1.3-1.1.7 significantly prevail.

Table 1 Declared unit and conversion factors

Identification	Unit	Value
Declared unit	t	1
Conversion factor from kg	kg	1000
Conversion factor from kg	kg	1000

2. System boundary according to the modular approach

The boundary of the product life cycle system consists of **the information module A1 – A3 "Production phase", "End of life cycle phase" C1-C4 and D** in accordance with EN 15804+A2:2019. The project report includes all relevant processes for the EPD type "**From cradle to gate with modules C1-C4 and module D**" (cradle to gate with modules C1–C4 and module D).

Information on product system boundaries is shown in Table 2.

Table 2: Information about product system boundaries – information modules

Information about product system boundaries – information modules (X = Included, ND = module not declared)																	
Production stage			Construction stage		Usage stage							End-of-life stage				Additional information beyond the life cycle	
Supply of mineral resources	Transport	Production	Transport to the construction site	Construction/installation process	Usage	Maintenance	Repair	Replacement	Reconstruction	Operational energy consumption	Operating water consumption	Demolition/deconstruction	Transport	Waste treatment	Removal	Benefits and costs beyond the system. Potential for reuse, recovery, and recycling	
A1	A2	A3	A4	A5	B1	B2	B3	B4	B5	B6	B7	C1	C2	C3	C4	D	
X	X	X	ND	ND	ND	ND	ND	ND	ND	ND	ND	X	X	X	X	X	

The **system boundary** is set to include both those processes that provide material and energy inputs to the system and subsequent production and transport processes up to the factory gate, and the treatment of all waste resulting from these processes.

The **production stage** includes the following modules:

- **A1** – extraction and processing of raw materials and production of packaging from input raw materials
- **A2** - transport of input raw materials from supplier to manufacturer, waste collection
- **A3** - production of products, production of auxiliary materials and semi-finished products, energy consumption, including treatment of waste, up to reaching end-of-waste or after the last material residues have been removed during the production phase.

Data for the period 2021 provided by FERT a.s. is used.

The **end-of-life stage** includes modules:

- **C1**, deconstruction, demolition; of the product from the building, including its dismantling or demolition, including the initial classification of materials at the site of construction

- **C2**, transport to the waste treatment site; transport of the discarded product as part of the waste treatment, e.g., to the recycling site, and transport of the waste, e.g., to the final disposal site.
- **C3**, treatment of waste for re-use, recovery and/or recycling, e.g., collection of waste fractions from deconstruction, treatment of waste from material flows intended for re-use, recycling, and energy recovery.
- **C4**, disposal of waste, including its pre-treatment and management of the disposal site

The benefits and costs beyond the product system are set out in Module D.

Module D includes:

- **D**, potential for reuse, recovery and/or recycling, expressed in net impacts or benefits.

The boundaries of the product system are considered in such a way that they **include only production processes, not administrative activities**.

As **end-of-life scenarios** for products (C1-C4, D), data resulting from an expert estimate of the possibility of reprocessing part of this glass insulation after the deconstruction of the building (as part of the take-back as a replacement for part of the inputs to production, reprocessing into another product – e.g., blown-in insulation, etc.) were used. These schemes are:

Module C1

Decomposition and/or dismantling of paving and cladding are part of the demolition of the entire building. In this case, it is assumed that the impact on the environment is very small and can be neglected.

Module C2

Transport from the dismantled building is carried out by a truck with a capacity of 7.5 - 16 t (EURO 6) to the recycling center, estimated transport distance: 100 km to the recycling center.

Module C3

100% is considered for the use of products as recyclable material (as steel scrap for input into steel production).

Module C4

The landfilling process is not considered.

Potential for reuse, recovery, and recycling (D)

In the module D scenario, the saving of primary raw material inputs – pig iron in another product system (steel production) is taken into account.

2.1. Preconditions and measures taken

Information modules **A4 to A5**, which are intended to provide additional information beyond the production stage, have not been included in the LCA due to the difficult availability of input data and are therefore not declared.

Information modules from the **usage stage B1 to B7** are also not declared because according to EN 16757 these types of products do not require maintenance, repair, or replacement during the normal life in the usage stage, provided that they are used correctly. Also, during the usage stage, they do not require consumption of energy or water.

The reference lifetime of the products is also not declared because of unavailability of representative data on the operating conditions in the usage stage of the product.

Within the studied product system, no co-products are formed.

For the study, all operational data related to the consumption of main and auxiliary materials for the production of the product, energy data, diesel consumption and the distribution of annual waste and emissions according to the plant records were taken. For all inputs and outputs considered, transport costs were considered or differences in transport distances were recognised.

From the point of view of the waste produced, only the waste clearly related to production activities was included in the analysis.

Some input data were converted to units that were needed for selected generic process data in the environmental impact assessment calculation program.

It is about:

- Energy data related to **diesel fuel** expressed in MJ - was determined by calculation based on data on the consumption of liters of diesel fuel and a coefficient of 0.845 kg/l for diesel fuel and an energy value of 42.6 MJ/kg.
- **Natural gas** consumption data expressed in kWh – were determined by converting from the consumed quantity to MJ (1 kWh = 3.6 MJ)

Data on the production of **waste** were taken from the continuous register of waste for the reference period.

2.2. Cut-off criteria

The processes required for the installation of production equipment and the construction of infrastructure were not included in the analysis. Also, maintenance processes and administrative processes are not included – inputs and outputs are balanced only for the production phase.

The analysis also did not include non-returnable packaging from input raw materials (for example lubricants), the amount of which is very small compared to other material inputs.

During production, there are no emissions that should be monitored and reported.

2.3. Sources of environmental data

All inputs and outputs were entered in SI units, namely:

- Material and auxiliary inputs and product outputs in kg, pcs, m³
- Sources used as energy input (primary energy), in MWh or MJ and GJ, including renewable energy sources (hydropower, wind energy)
- Water consumption in kg or m³
- Inputs related to transport in km (distance), tkm (material transfer) and in kg (diesel consumption)
- Time was stated in practical units depending on the scale of the assessment: minutes, hours, days, years.

The time range of the required specific data, provided by the organization FERT a.s., for the processing of this report was set as a representative time period of the calendar year 2021. The basic source of the necessary data from the area of production, purchasing, maintenance, etc. was the information system, or operational records from maintenance activities. The annual report on waste production from the ISPOP system and operational records for the given production plant were used to assess waste production. Only those types of waste related to the production phase were included in this report, as waste destined for landfill.

The verified and registered EPD of the manufacturer Pittini Group, Italy (Reg. No. EPDITALY 0091) was used for the input of data on the environmental impact indicators of steel rolled wire.

For the following inputs it was proceeded this way (direct data not available):

- Distances on the transport of inputs and outputs (waste) – data from Google maps were used

For the complete analysis of environmental parameters were used:

- computing software SimaPro, version 9.4 SimaPro Analyst (database Ecoinvent version 3.8)

2.4. Data quality

The data used to calculate the EPD meet the following principles:

Time period: For specific data, manufacturer's data from 2021 have been used. This is due to significant technological changes in the production process. For generic data, the data of the Ecoinvent version database 3.8 have been used. Based on the evaluation in accordance with EN 15804+A2, Annex E, tab. E.1 the generic data used meet the quality level - very good.

Technological aspect: Data corresponding to the current production of individual types of sub-products and corresponding to the current state of new technologies in the plant used have been used.

Based on the evaluation in accordance with EN 15804+A2, Annex E, tab. E.1 the generic data used meet the level of quality - very good.

Completeness and complexness aspect: Most of the input data is based on consumption balances, which are precisely recorded in the information system. As part of the completeness check, the company FERT a.s. was visited, and it was checked whether all used inputs/outputs are entered in the records. The reliability of the source of specific data is determined by the uniformity of the methodology of the information system collection method.

Geographical aspect: The generic data used from the Ecoinvent database are used with validity for the Czech Republic (e.g., energy inputs) and if data are not available for the Czech Republic, data valid for the EU or according to the supplier's location are used. Based on the evaluation according to EN 15804+A2, Annex E, tab. E.1 used generic data meet the level of quality - medium.

Consistency aspect: Uniform aspects are used throughout the scope of the report (allocation rules, age of data, technological scope of validity, time scope of validity, geographical scope of validity).

Credibility aspect: All important data were checked to ensure cross-comparison of weight balances.

2.5. Period considered

As the period of the required specific data, provided by FERT a.s., for the purpose of this report, a calendar period **2021** was determined as a representative period.

2.6. Allocation

In the balance of inputs, their direct monitoring was used at individual centres, or allocation based on weight was used.

2.7. Comparability

Environmental product declarations from different programmes may not be comparable. Comparison or assessment of EPD data is only possible if all compared data reported in accordance with EN 15804+A2:2019 have been determined according to the same rules.

2.8. Product variability

The resulting data are given for **1 t of average product – Reinforcing steel**.

2.9. LCA: Results

Information on environmental impacts is indicated in the following tables. The individual results for the impact categories are presented in Tables 3 and 4. Tables 5 to 7 provide additional environmental information. They are related to the declared unit (DJ) – **1 t of the average product - Reinforcing steel**.

The impact assessment was carried out using the characterisation factors used in the European Life Cycle Reference Database (ELCD) provided by the European Commission – Directorate-General of the Joint Research Centre – Institute for Environment and Sustainability.

Table 3: Parameters describing the basic environmental impacts

Ultimately LCA – Parameters describing basic environmental impacts (DJ = 1 t of the product)							
Indicator	Unit	A1-A3	C1	C2	C3	C4	D
Global warming potential (GWP-total)	kg CO ₂ ekv.	9,16E+02	5,79E+01	4,29E+01	2,46E+01	0,00E+00	-4,77E+02
Global warming potential (GWP-fossil)	kg CO ₂ ekv.	9,48E+02	5,78E+01	4,29E+01	2,50E+01	0,00E+00	-4,37E+02
Global warming potential (GWP-biogenic)	kg CO ₂ ekv.	-3,20E+01	9,09E-02	3,89E-02	-4,40E-01	0,00E+00	-3,95E+01
Global warming potential from land use and land-use change (GWP-luluc)	kg CO ₂ ekv.	6,33E-01	6,02E-03	2,02E-02	4,76E-02	0,00E+00	-2,32E-01
Stratospheric ozone depletion potential (ODP)	kg CFC 11 ekv.	1,16E-04	1,23E-05	9,64E-06	3,32E-06	0,00E+00	-2,08E-05
Acidification potential, Cumulative exceedance (AP)	mol H ⁺ ekv.	4,40E+00	6,00E-01	1,70E-01	2,97E-01	0,00E+00	-2,82E+00
Eutrophication potential, proportion of nutrients entering fresh water (freshwater EP)	kg P ekv.	4,21E-01	1,92E-03	3,22E-03	1,58E-02	0,00E+00	-7,42E-02
Eutrophication potential, proportion of nutrients entering seawater (seawater EP)	kg N ekv.	9,73E-01	2,65E-01	4,96E-02	6,74E-02	0,00E+00	-6,75E-01
Eutrophication potential, Cumulative overshoot (soil EP)	mol N ekv.	1,00E+01	2,91E+00	5,42E-01	7,55E-01	0,00E+00	-7,58E+00
Ground-level ozone formation potential (POCP)	kg NMVOC ekv.	3,05E+00	8,00E-01	1,67E-01	2,08E-01	0,00E+00	-3,19E+00
Raw material depletion potential for non-fossil sources (ADP-minerals and metals)	kg Sb ekv.	3,53E-03	4,32E-05	1,95E-04	2,96E-03	0,00E+00	-3,28E-04
Raw material depletion potential for fossil resources (ADP-fossil fuels)	MJ, calorific value	1,39E+04	8,04E+02	6,40E+02	3,45E+02	0,00E+00	-2,72E+03
Water scarcity potential (for users), water scarcity weighted by water scarcity (WDP)	m ³ eq. scarcity	2,29E+02	1,35E+00	2,12E+00	4,55E+00	0,00E+00	-2,00E+01

Table 4 Parameters describing additional environmental impacts

LCA result – Parameters indicating additional environmental impacts (DJ = 1 t of the product)							
Indicator	Unit	A1-A3	C1	C2	C3	C4	D
Potential occurrence of disease due to particulate matter emissions (PM)	Occurrence of the disease	1,44E-04	1,61E-05	3,19E-06	3,99E-06	0,00E+00	-4,85E-05
Potential effect of human exposure to the isotope U235 (IRP)	kBq U235 eq.	5,58E+01	4,32E+00	3,40E+00	3,54E+00	0,00E+00	-1,61E+01
Potential comparative toxic unit for ecosystems (ETP-fw)	CTUe	6,78E+03	4,71E+02	5,22E+02	1,27E+03	0,00E+00	-1,46E+04
Potential comparative toxic unit for humans (HTP-c)	CTUh	3,70E-05	3,45E-07	5,28E-07	1,87E-06	0,00E+00	-2,28E-05
Potential comparative toxic unit for humans (HTP-nc)	CTUh	6,75E-06	1,86E-08	1,91E-08	4,27E-08	0,00E+00	-1,15E-06
Potential Soil Quality Index (SQP)	dimensionless	3,40E+03	1,17E+02	3,78E+02	6,37E+02	0,00E+00	-7,36E+02

Table 5: Parameters describing resource consumption

LCA result – Parameters describing resource consumption (DJ = 1 t of the product)							
Parameter	Unit	A1-A3	C1	C2	C3	C4	D
Consumption of renewable primary energy, excluding energy sources used as raw materials (PERE)	MJ	8,52E+02	1,63E+01	1,08E+01	5,36E+01	0,00E+00	-1,24E+02
Consumption of renewable primary energy sources used as raw materials (PERM)	MJ	1,08E+02	0,00E+00	0,00E+00	0,00E+00	0,00E+00	0,00E+00
Total consumption of renewable primary energy sources (primary energy and primary energy sources used as raw materials) (PERT)	MJ	9,60E+02	1,63E+01	1,08E+01	5,36E+01	0,00E+00	-1,24E+02
Consumption of non-renewable primary energy, excluding energy sources used as raw materials (PENRE)	MJ	3,94E+03	8,53E+02	6,79E+02	3,66E+02	0,00E+00	-2,88E+03
Consumption of non-renewable primary energy sources used as raw materials (PENRM)	MJ	9,91E+03	0,00E+00	0,00E+00	0,00E+00	0,00E+00	0,00E+00
Total consumption of non-renewable primary energy sources (primary energy and primary energy sources used as raw materials) (PENRT)	MJ	1,39E+04	8,53E+02	6,79E+02	3,66E+02	0,00E+00	-2,88E+03
Consumption of secondary raw materials (SM)	kg	8,17E+02	0,00E+00	0,00E+00	0,00E+00	0,00E+00	0,00E+00
Consumption of renewable secondary fuels (RSF)	MJ	0,00E+00	0,00E+00	0,00E+00	0,00E+00	0,00E+00	0,00E+00
Consumption of non-renewable secondary fuels (NRSF)	MJ	0,00E+00	0,00E+00	0,00E+00	0,00E+00	0,00E+00	0,00E+00
Net potable water consumption (FW)	m ³	4,90E+00	0,00E+00	0,00E+00	0,00E+00	0,00E+00	0,00E+00

Table 6 Other environmental information - waste category description

LCA result — Other environmental information — waste category description (DJ = 1 t of the product)							
Parameter	Unit	A1-A3	C1	C2	C3	C4	D
Hazardous waste disposed of (HWD)	kg	0	0	0	0	0	0
Other waste disposed of (NHWD)	kg	0	0	0	0	0	0
Radioactive waste disposed of (RWD)	kg	0	0	0	0	0	0

Table 7 Other environmental information - description of output flows

LCA result - Other environmental information - description of output flows (DJ = 1 t of the product)							
Parameter	Unit	A1-A3	C1	C2	C3	C4	D
Construction units for reuse (MFR)	kg	0	0	0	0	0	0
Materials for recycling (MER)	kg	1,37E+01	0	0	1,00E+03	0	0
Materials for energy recovery (EEE)	kg	2,12E+01	0	0	0	0	0
Exported energy (EET)	MJ per energy carrier	0	0	0	0	0	3,25E+02

Table 8 Information describing the **biogenic carbon content** of the plant gate

LCA result – Information describing the biogenic carbon content at the plant gate (DJ = 1 t of the product)		
Parameter	Unit	At the plant gate
Biogenic carbon content of the product	kg C	0
Biogenic carbon content in the appropriate packaging	kg C	5,50E+01

2.9.1. LCA: Interpretation

The impact of basic groups of inputs on basic environmental impacts is shown in Figure 3:

Figure. 3 Impact of the share of basic inputs on the basic impacts

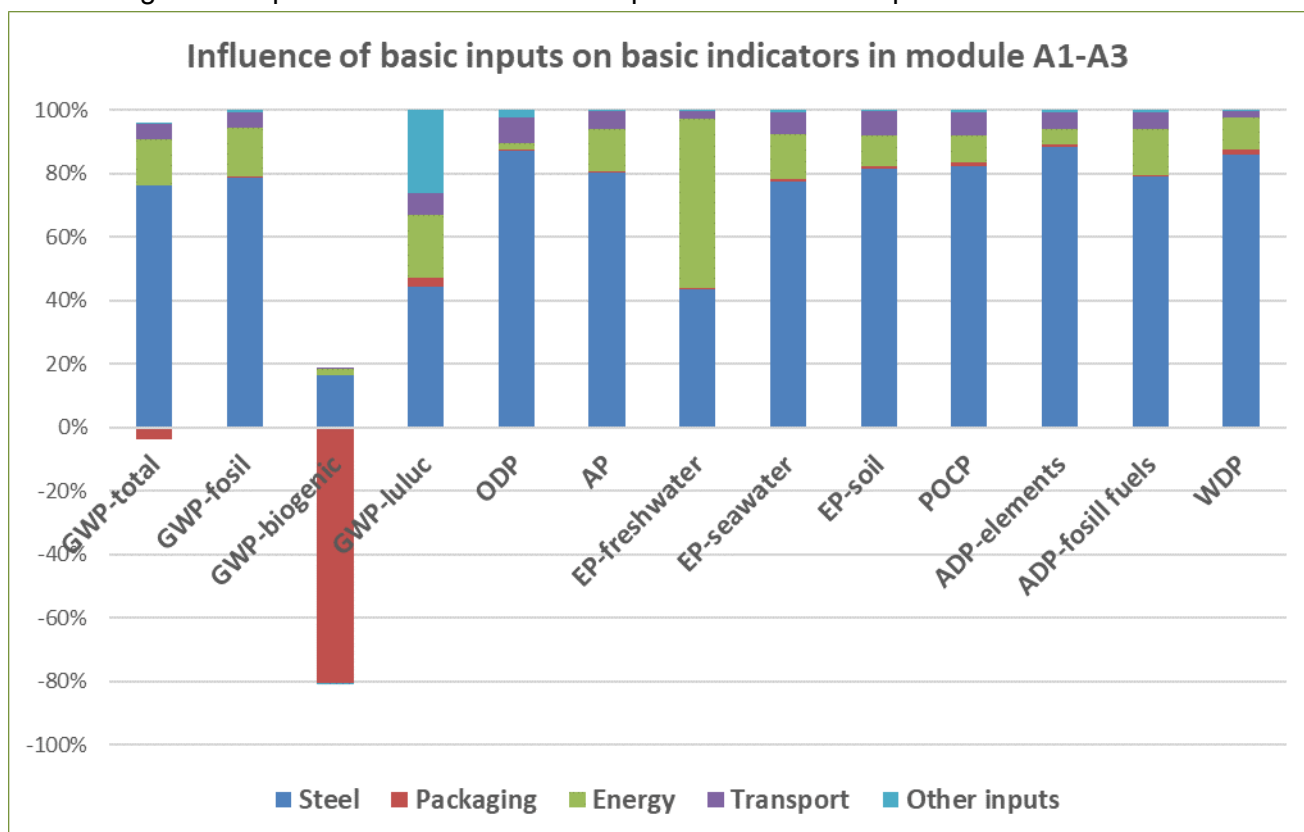

It can be seen from the figure that the **consumption of steel and electricity** (energy mix of the Czech Republic) has a very significant influence on environmental impacts. To a lesser extent, the effect of **transport** is also applied.

3. LCA: scenarios and other technical information

Information modules A4, A5 and B1-B7 were not included in the LCA analysis.

4. LCA: Additional information

EPD does not include additional documentation related to the declaration of supplementary information.

5. References

ČSN ISO 14025:2010 Environmentální značky a prohlášení - Environmentální prohlášení typu III - Zásady a postupy (Environmental labels and declarations - Type III environmental declarations - Principles and procedures)

ČSN EN 15804+A2:2019 Udržitelnost staveb - Environmentální prohlášení o produktu - Zásadní pravidla pro produktovou kategorii stavebních výrobků (Sustainability of construction works - Environmental product declarations - Core rules for the product category of construction products)

ČSN EN ISO 14040:2006 Environmentální management - Posuzování životního cyklu - Zásady a osnova (Environmental management - Life Cycle Assessment - Principles and Framework)

ČSN EN ISO 14044:2006 Environmentální management - Posuzování životního cyklu – Požadavky a směrnice (Environmental management - Life Cycle Assessment – Requirements and guidelines)

ČSN ISO 14063:2007 Environmentální management - Environmentální komunikace - Směrnice a příklady (Environmental management - Environmental communication - Guidelines and examples)

ČSN EN 15643-1:2011 Udržitelnost staveb - Posuzování udržitelnosti budov - Část 1: Obecný rámec (Sustainability of construction works - Sustainability assessment of buildings - Part 1: General framework)

ČSN EN 15643-2:2011 Udržitelnost staveb - Posuzování udržitelnosti budov - Část 2: Rámec pro posuzování environmentálních vlastností (Sustainability of construction works - Assessment of buildings - Part 2: Framework for the assessment of environmental performance)

ČSN EN 15942:2013 Udržitelnost staveb - Environmentální prohlášení o produktu - Formát komunikace mezi podniky (Sustainability of construction works - Environmental product declarations - Communication format business-to-business)

TNI CEN/TR 15941:2012 Udržitelnost staveb - Environmentální prohlášení o produktu - Metodologie výběru a použití generických dat (Sustainability of construction works - Environmental product declarations - Methodology for selection and use of generic data)

ČSN EN 16449:2014 Dřevo a výrobky na bázi dřeva - Výpočet obsahu biogenního uhlíku ve dřevě a přeměny na oxid uhličitý (Wood and wood-based products - Calculation of the biogenic carbon content of wood and conversion to carbon dioxide) LCD handbook - JRC EU, 2011

Zákon č. 541/2020 Sb. v platném znění (Zákon o odpadech)

Vyhláška č. 8/2021 Sb. Katalog odpadů – Katalog odpadů

Nařízení Evropského parlamentu č. 1907/2006 o registraci, hodnocení, povolování a omezování chemických látek a o zřízení Evropské agentury pro chemické látky - REACH (registrace, evaluace a autorizace chemických látek)

Nařízení Evropského parlamentu a Rady (ES) č. 1272/2008 o klasifikaci, označování a balení látek a směsí, o změně a zrušení směrnic 67/548/EHS a 1999/45/ES a o změně nařízení (ES) č. 1907/2006 (nařízení CLP)

SimaPro LCA Package, Pré Consultants, the Netherlands , www.pre-sustainability.com

Ecoinvent Centre, www.Ecoinvent.org

Explanatory documents are available at the sales department of FERT a.s.

6. EPD Verification

Independent verification of declaration in accordance with ČSN ISO 14025:2010			
The ČSN EN 15804+A2 standard produced by CEN serves as the basic PCR ^a			
<input type="checkbox"/>	interní	<input checked="" type="checkbox"/>	externí
Third-party verifier: ^b :			
Elektrotechnický zkušební ústav s.p. Pod Lisem 129 171 02 Praha 8 – Troja Czech Republic		 Mgr. Miroslav Sedláček Head of the Certification Body	
Certification body for EPD, accredited by CIA, Czech Accreditation Institute under no. 3018			
^a Product category rules ^b Optional for business communication, mandatory for business-to-consumer communication (see ISO 14025:2010, clause 9.4).			

This document is a translation of the EPD issued in Czech. In case of doubt use the Czech version of this EPD as a reference.

	Organisation FERT a.s. Petra Bezruče 447/14 392 01 Soběslav - Soběslav II, CZ	Tel: +420 381 521 166 +420 734 274 149 Email: simonafau@fert.cz, Web: https://www.fert.cz/
	Branch operator of the programme: CENIA, Czech Environmental Information Agency, executive body of the NPEZ Agency Moskevská 1523/63 100 10 Prague 10	Tel: +420 267 225 226 Fax: - Email: info@cenia.cz Web: www.cenia.cz
	Elaborated by: Technický a zkušební ústav stavební Praha, s.p. Branch Plzeň Zahradní 15 326 00 Plzeň, CZ	Tel. : +420 734 432 137 +420 602 185 785 vrbova@tzus.cz trinner@tzus.cz