

# COMPACT BEARING S 70

Unreinforced elastomeric bearing loadable to 21 N/mm<sup>2</sup>

# SECURELY AND PERMANENTLY BEDDED

ENHANCING LIVING COMFORT WITH CALENBERG

Premium grade rubber material and a high quality standard in our elastomer bearings guarantee freedom from maintenance, a long service life and consequently ensure absolute damage-free construction.

KNOW  
HOW





## Prevention of structural damage

Permanent loads (e.g. inherent weight of the structure), variable influences (e.g. wind) and constraining forces (e.g. from temperature changes, creep, component tolerances or settlements) result in deformations of structural components. Without the use of suitable elastomeric bearings, these impacts mentioned will cause damage to structures. In addition to cracks and spalling, there can also be large-scale destruction of the adjacent components, which need to be repaired at considerable expense in terms of time and cost.

In component connections, the elastic effect of the structural bearings transfers forces centrally and at the same time compensates for plane-parallel deviations. Shear deformations from non-permanent horizontal effects are absorbed by the elastomer bearings.

### Advantages for our customers

The extremely high bearing loads of the bearings enable filigree and cost-effective structural designs. Elastomer bearings do not require maintenance and do not need to be replaced if correctly dimensioned and installed. The designers also secure the material reserves in the event of unforeseen load conditions. The service life of the construction bearings is at least equal to the service life of the adjacent components. Our elastomeric bearings increase the value of the building by avoiding structural damage and eliminating renovation and maintenance costs. The static elastomeric bearings transmit forces, twists and displacements into the adjacent components permanently and damage-free.

### Product features

- Simple design (shape factor based)
- Maintenance free
- Weather and ozone resistant
- Extremely durable
- Very low creep behaviour
- Premium grade material (EPDM)
- Approved by building authorities

## The Compact bearing S 70

### Product description

The Calenberg Compact Bearing S 70 is an unreinforced elastomeric bearing with smooth contact surfaces. The main component is an ageing resistant EPDM elastomeric material with a hardness of  $70 \pm 5$  Shore A. The material is weather and ozone resistant.

### Use and areas of application

Calenberg Compact Bearings S 70 are used in all areas of construction as permanently elastic articulating connection elements. In building construction they are mostly used as point bearings for providing elastic support for beams and joists. In multi-storey buildings they are also used as strip bearings under deck structures and on wall sections.

### Building authority approval

The approval for use as a construction bearing in building construction is regulated by the standard building authority certification Z-16.32-477, issued by the Deutsches Institut für Bautechnik.

### Behaviour in fire

For fire safety requirements, the fire safety report No. 3799/7357-AR by the Technical University (TU) of Braunschweig shall be taken into account. The report describes the minimum dimensions and other measures that meet the requirements of DIN 4102-2.

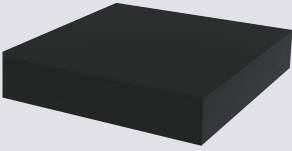
EXCERPT FROM THE TECHNICAL DATA				
	Type of bearing	Bearing thickness [mm]	Compressive stress	Approval
	Unreinforced deformation bearing	5*	$\sigma_{R,d} \leq 21 \text{ N/mm}^2$	Approval no. Z-16.32-477, issued by the DIBt Berlin
		8*		
		10		
		15		
		20		

\* without building authority approval



## Delivery forms

Calenberg Compact Bearings S 70 are supplied in almost any desired dimension for the specific structure. The bearings can be provided with holes, cut-outs, slots, etc.

The bearings are embedded in polystyrene at the factory and equipped with a watertight plastic cover for in-situ concrete construction.

For fire protection requirements, a Ciflamon fire protection board with a width of at least 30 mm shall be provided if required.

### STANDARD CUT-OUTS

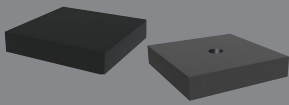

Hole



Corner notch



Slot



Rectangular notch



Slit notch



Rectangular hole



Diagonal cut



### DIMENSIONS

Bearing thickness	Maximum cut size	Minimum cut size	Minimum width
10, 15, 20, 25, 30 mm	1200 mm x 1200 mm	70 mm x 70 mm für $b_1 \geq 100$ mm also $a_1 \geq 50$ mm	5 x bearing thickness

Point and strip bearings in precast construction



Point and strip bearings in in-situ construction  
embedded in polystyrene or Ciflamon with cover







The bearing areas must be designed in accordance with the structural specifications and standards. The required edge distances shall be taken into account in accordance with DIN EN 1992-1-1 (2011-01). The elastomeric bearing must be located within the reinforcement in order to allow planned deformation of the bearing and to avoid spalling at the edge.

RANDABSTAND DRAUFSICHT

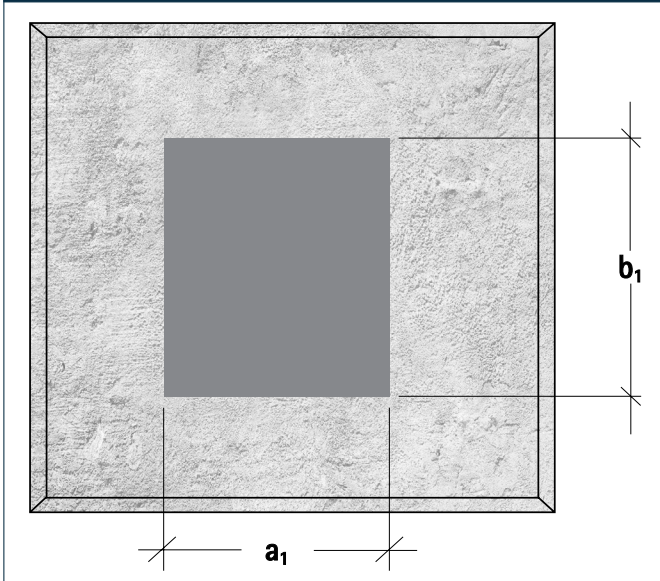

RANDABSTAND SEITENSICHT

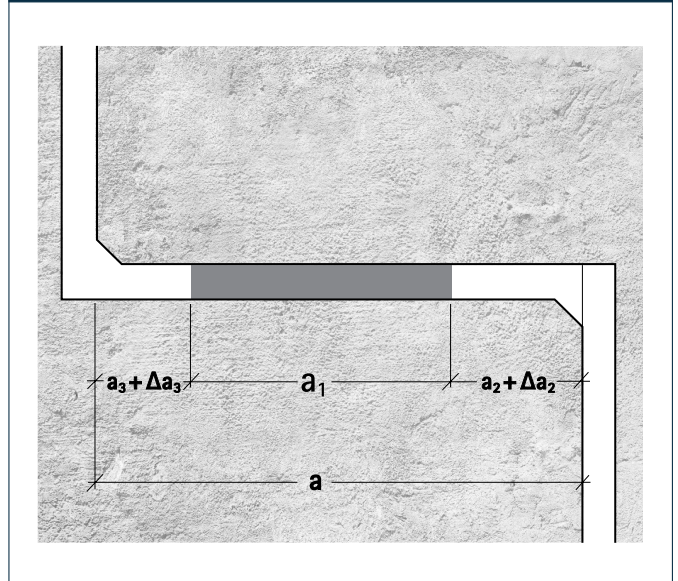

## LEGEND

Values for determining the required edge distances according to DIN EN 1992-1-1

$a$  |  $a_1$  |  $a_2$  |  $\Delta a_2$  |  $a_3$  |  $\Delta a_3$  |  $b_1$

## Extract from the installation instructions



Prior to installation, it must be ensured that the elastomer bearings and bearing surfaces are free of dirt, ice, snow, grease, solvents, oils or separating agents.

In in-situ concrete construction the bearing joints must be filled and covered so that no concrete slurry can penetrate them. The spring effect of the bearing must be guaranteed.



## Extract from our client reference projects

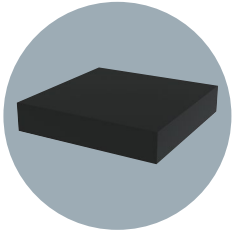

### COMPACT BEARING S 70

- Byldis, London, Great Britain, 2019
- Aurelis, Dresden, Germany, 2019
- Zalando, Lodz, Poland, 2017
- Möbelhaus XXXL Uffenheim, Germany, 2017
- VW Plant, Bratislava, Slovakia, 2016
- BMW Logistic Centre, Germany, 2016
- Amazon Pforzheim, Germany, 2012
- Citti-Park, Lübeck, Germany, 2008
- Bobsleigh-Skeleton-Luge Track, Oberhof, Germany, 2008



Byldis, Great Britain



Bobsleigh-Skeleton-Luge Track, Germany

## COMPACT BEARING S 70

Structural bearing for static structural members

### Design values

The bearings are dimensioned according to the general building authority approval up to a compressive stress  $\sigma_{R,d} = 21 \text{ N/mm}^2$ . The design concept is based on the shape factor. Holes, cut-outs and the required edge distances must be taken into account according to DIN EN 1992.

#### TYPE OF LOAD ACTING

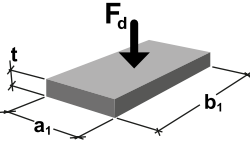
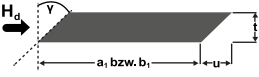
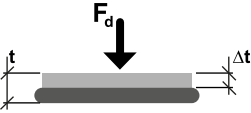
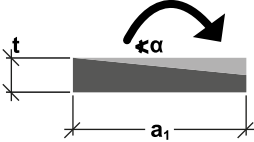
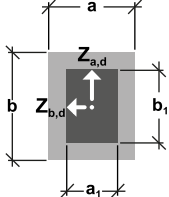
Design value of bearing resistance	All. shear deformation	Deflection	Allowable rotation	Transverse tensile forces*
				

#### FORMEL

$\sigma_{R,d} = 7 \cdot S \leq 21 \text{ [N/mm}^2\text{]}$	all. $u = 0,6 \cdot (t-2) \text{ [mm]}$		all. $\alpha = \frac{450 \cdot t}{a_1} \leq 40 \text{ [‰]}$ (Rectangular bearing) Additional rotation acc. to technical approval: • 10 ‰ from obliquity • $\frac{625}{a_1}$ from unevenness see also booklet 600, DAfStb	$Z_{a,d} = 1,5 \cdot F_d \cdot t / b_1 \text{ [kN]}$ (perpendicular to bearing short side) $Z_{b,d} = 1,5 \cdot F_d \cdot t / a_1 \text{ [kN]}$ (perpendicular to bearing long side) *see also booklet 339, DAfStb
Shape factor S see page 2	Horizontal force $H_d = c_{s(t)} \cdot u \cdot A_E / 20000 \text{ [kN]}$ A minimum compressive stress of $2 \text{ N/mm}^2$ is required to prevent the bearing from slipping. $c_{s(t)}$ values and boundary conditions, see page 8	See page 6		

#### LEGENDE FORMELZEICHEN

$F_d$	Vertical force	$\sigma_{R,d}$	Design value of the load capacity
$H_d$	Horizontal force	$\sigma_{E,d}$	Design compressive stress from load
$Z_{a,d}, Z_{b,d}$	Transverse tensile force	$\alpha$	Bearing rotation
$A_E$	Bearing area	$c_{s(t)}$	Shear stiffness
S	Shape factor, Ratio of pressed bearing surface $A_E$ to unloaded lateral surface	u	Shear deformation of the bearing
$a_1$	Short side of bearing	$\gamma$	Push angle
$b_1$	Long side of bearing	t	Thickness of bearing
a	Component width	$\Delta t$	Bearing deflection
b	Component length		



## COMPACT BEARING S 70

Structural bearing for static structural members

### Design of the shape factor

For the design of unreinforced elastomeric bearings, the shape factor  $S$  is defined as the ratio of the compressed to the freely deformable surface. The shape factor  $S$  is used to calculate the permissible compressive stress as a function of the bearing dimensions.

#### SHAPE FACTOR FOR RECTANGULAR BEARING

Without drilled holes

$$S = \frac{b_1 \cdot a_1}{2 \cdot t \cdot (b_1 + a_1)}$$

With drilled holes,  $n \leq 2$

$$S = \frac{a \cdot b - \frac{\pi}{4} n \cdot d^2}{2 \cdot t \cdot (a + b) + t \cdot \pi \cdot n \cdot d}$$

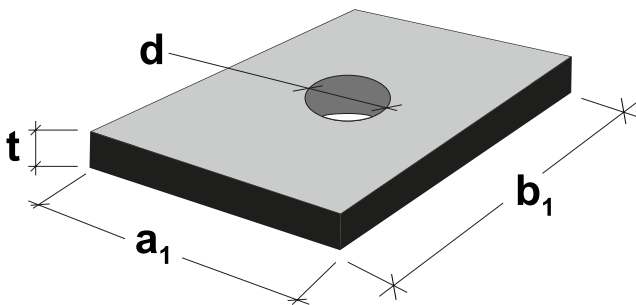

#### SHAPE FACTOR FOR BEARING STRIP

$$S = \frac{a_1}{2 \cdot t} \quad b_1 \gg a_1$$

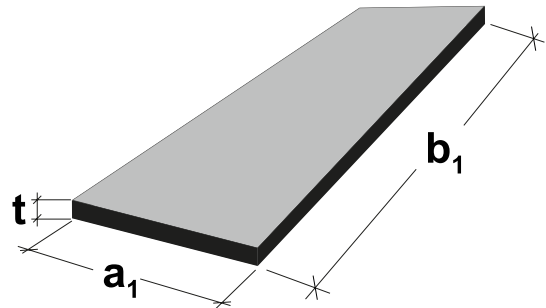

#### SHAPE FACTOR FOR CIRCULAR BEARING

Without drilled holes

$$S = \frac{D}{4 \cdot \sqrt{2} \cdot t}$$

With drilled holes

$$S = \frac{D - d}{4 \cdot \sqrt{2} \cdot t}$$

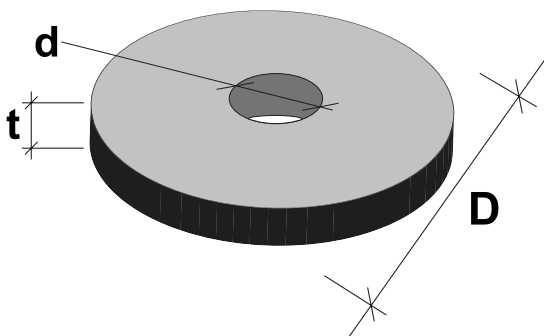

## COMPACT BEARING S 70

Structural bearing for static structural members

### Thicknesses: 10 and 15 mm

The following tables show the design value of the load capacity and the allowable angle of distortion as a function of the bearing dimensions. Intermediate values may be interpolated.

BEARING			DESIGN VALUE OF THE LOAD CAPACITY, $\sigma_{R,d}$ [N/mm <sup>2</sup> ]																			
[mm]	$\alpha$ [‰]	[mm]	BEARING LENGTH [mm]																			
Thick-ness	all. rotation	Width	70	80	90	100	110	120	130	140	150	175	200	225	250	275	300	350	400	450	500	
			10		40,0	50	-	-	-	11,7	12,0	12,4	12,6	12,9	13,1	13,6	14,0	14,3	14,6	14,8	15,0	15,3
	40,0	60		-	-	-	13,1	13,6	14,0	14,4	14,7	15,0	15,6	16,2	16,6	16,9	17,2	17,5	17,9	18,3	18,5	18,8
	40,0	70		12,3	13,1	11,8	14,4	15,0	15,5	15,9	16,3	16,7	17,5	18,1	18,7	19,1	19,5	19,9	20,4	20,9		
	40,0	80		13,1	14,0	12,7	15,6	16,2	16,8	17,3	17,8	18,3	19,2	20,0	20,7							
	40,0	90		13,8	14,8	13,5	16,6	17,3	18,0	18,6	19,2	19,7	20,8									
	40,0	100		14,4	15,6	14,2	17,5	18,3	19,1	19,8	20,4											
	40,0	110		15,0	16,2	14,9	18,3	19,3	20,1	20,9												
	37,5	120		15,5	16,8	15,4	19,1	20,1														
	34,6	130		15,9	17,3	16,0	19,8	20,9														
	32,1	140		16,3	17,8	16,4	20,4															
	30,0	150		16,7	18,3	16,9																
	28,1	160		17,0	18,7	17,3																
	25,7	175		17,5	19,2	17,8																
	22,5	200		18,1	20,0	18,6																
	18,0	250		19,1		19,9																
	15,0	300		19,9		20,8																
	12,9	350		20,4																		
	11,3	400		20,9																		
	10,0	450																				
	9,0	500																				
	8,2	550																				
	7,5	600																				

21,0

BEARING			DESIGN VALUE OF THE LOAD CAPACITY, $\sigma_{R,d}$ [N/mm <sup>2</sup> ]																			
[mm]	$\alpha$ [‰]	[mm]	BEARING LENGTH [mm]																			
Thick-ness	all. rotation	Width	75	80	90	100	110	120	130	140	150	175	200	225	250	275	300	350	400	450	500	
			15		40,0	75	8,8	9,0	9,5	10,0	10,4	10,8	11,1	11,4	11,7	12,3	12,7	13,1	13,5	13,8	14,0	14,4
	40,0	80		9,0	9,3	9,9	10,4	10,8	11,2	11,6	11,9	12,2	12,8	13,3	13,8	14,1	14,5	14,7	15,2	15,6	15,8	16,1
	40,0	90		9,5	9,9	10,5	11,1	11,6	12,0	12,4	12,8	13,1	13,9	14,5	15,0	15,4	15,8	16,2	16,7	17,1	17,5	17,8
	40,0	100		10,0	10,4	11,1	11,7	12,2	12,7	13,2	13,6	14,0	14,8	15,6	16,2	16,7	17,1	17,5	18,1	18,7	19,1	19,4
	40,0	110		10,4	10,8	11,6	12,2	12,8	13,4	13,9	14,4	14,8	15,8	16,6	17,2	17,8	18,3	18,8	19,5	20,1	20,6	
	40,0	120		10,8	11,2	12,0	12,7	13,4	14,0	14,6	15,1	15,6	16,6	17,5	18,3	18,9	19,5	20,0	20,9			
	40,0	130		11,1	11,6	12,4	13,2	13,9	14,6	15,2	15,7	16,3	17,4	18,4	19,2	20,0	20,6					
	40,0	140		11,4	11,9	12,8	13,6	14,4	15,1	15,7	16,3	16,9	18,1	19,2	20,1	20,9						
	40,0	150		11,7	12,2	13,1	14,0	14,8	15,6	16,3	16,9	17,5	18,8	20,0								
	40,0	160		11,9	12,4	13,4	14,4	15,2	16,0	16,7	17,4	18,1	19,5	20,7								
	38,6	175		12,3	12,8	13,9	14,8	15,8	16,6	17,4	18,1	18,8	20,4									
	33,8	200		12,7	13,3	14,5	15,6	16,6	17,5	18,4	19,2	20,0										
	27,0	250		13,5	14,1	15,4	16,7	17,8	18,9	20,0	20,9											
	22,5	300		14,0	14,7	16,2	17,5	18,8	20,0													
	19,3	350		14,4	15,2	16,7	18,1	19,5	20,9													
	16,9	400		14,7	15,6	17,1	18,7	20,1														
	15,0	450		15,0	15,8	17,5	19,1	20,6														
	13,5	500		15,2	16,1	17,8	19,4															
	12,3	550	15,4	16,3	18,0	19,7																
	11,3	600	15,6	16,5	18,3	20,0																

21,0

Use in in-situ concrete: Embedding in polystyrene

Use in fire resistance class F90 / F120: If necessary, embedding in Ciflamon fire protection panel

## COMPACT BEARING S 70

Structural bearing for static structural members

Thickness: 20 mm

BEARING			DESIGN VALUE OF THE LOAD CAPACITY, $\sigma_{R,d}$ [N/mm <sup>2</sup> ]																
[mm]	$\alpha$ [‰]	[mm]	BEARING LENGTH [mm]																
Thick- ness	all- rotation	Width	100	110	120	125	130	140	150	175	200	225	250	275	300	350	400	450	500
			20	40,0	100	8,8	9,2	9,5	9,7	9,9	10,2	10,5	11,1	11,7	12,1	12,5	12,8	13,1	13,6
40,0	110	9,2		9,6	10,0	10,2	10,4	10,8	11,1	11,8	12,4	12,9	13,4	13,8	14,1	14,6	15,1	15,5	15,8
40,0	120	9,5		10,0	10,5	10,7	10,9	11,3	11,7	12,5	13,1	13,7	14,2	14,6	15,0	15,6	16,2	16,6	16,9
40,0	130	9,9		10,4	10,9	11,2	11,4	11,8	12,2	13,1	13,8	14,4	15,0	15,4	15,9	16,6	17,2	17,7	18,1
40,0	140	10,2		10,8	11,3	11,6	11,8	12,3	12,7	13,6	14,4	15,1	15,7	16,2	16,7	17,5	18,1	18,7	19,1
40,0	150	10,5		11,1	11,7	11,9	12,2	12,7	13,1	14,1	15,0	15,8	16,4	17,0	17,5	18,4	19,1	19,7	20,2
40,0	160	10,8		11,4	12,0	12,3	12,6	13,1	13,5	14,6	15,6	16,4	17,1	17,7	18,3	19,2	20,0	20,7	
40,0	175	11,1		11,8	12,5	12,8	13,1	13,6	14,1	15,3	16,3	17,2	18,0	18,7	19,3	20,4			
40,0	200	11,7		12,4	13,1	13,5	13,8	14,4	15,0	16,3	17,5	18,5	19,4	20,3					
36,0	250	12,5		13,4	14,2	14,6	15,0	15,7	16,4	18,0	19,4	20,7							
30,0	300	13,1		14,1	15,0	15,4	15,9	16,7	17,5	19,3									
25,7	350	13,6		14,6	15,6	16,1	16,6	17,5	18,4	20,4									
22,5	400	14,0		15,1	16,2	16,7	17,2	18,1	19,1										
20,0	450	14,3		15,5	16,6	17,1	17,7	18,7	19,7										
18,0	500	14,6		15,8	16,9	17,5	18,1	19,1	20,2										
16,4	550	14,8	16,0	17,2	17,8	18,4	19,5	20,6											
15,0	600	15,0	16,3	17,5	18,1	18,7	19,9												

21,0

Use in in-situ concrete: Embedding in polystyrene

Use in fire resistance class F90 / F120: If necessary, embedding in Ciflamon fire protection panel

## COMPACT BEARING S 70

Structural bearing for static structural members

STRIP BEARINGS						
BEARING WIDTH $a_1$ [mm]	COMPACT BEARING S 70					
	BEARING THICKNESSES					
	t = 10 mm		t = 15 mm		t = 20 mm	
	$F_{R,d}$ [kN/m]	all. $\alpha$ [‰]	$F_{R,d}$ [kN/m]	all. $\alpha$ [‰]	$F_{R,d}$ [kN/m]	all. $\alpha$ [‰]
50	875	40,0	-	-	-	-
60	1260	40,0	-	-	-	-
70	1470	40,0	-	-	-	-
80	1680	40,0	1493	40,0	-	-
90	1890	40,0	1890	40,0	-	-
100	2100	40,0	2100	40,0	1750	40,0
110	2310	40,0	2310	40,0	2118	40,0
120	2520	37,5	2520	40,0	2520	40,0
130	2730	34,6	2730	40,0	2730	40,0
140	2940	32,1	2940	40,0	2940	40,0
150	3150	30,0	3150	40,0	3150	40,0
160	3360	28,1	3360	40,0	3360	40,0
170	3570	26,5	3570	39,7	3570	40,0
180	3780	25,0	3780	37,5	3780	40,0
190	3990	23,7	3990	35,5	3990	40,0
200	4200	22,5	4200	33,8	4200	40,0
210	4410	21,4	4410	32,1	4410	40,0
220	4620	20,5	4620	30,7	4620	40,0
230	4830	19,6	4830	29,3	4830	39,1
240	5040	18,8	5040	28,1	5040	37,5
250	5250	18,0	5250	27,0	5250	36,0

Use in in-situ concrete: Embedding in polystyrene  
 Use in fire resistance class F90 / F120: If necessary, embedding in Ciflamon fire protection panel

## COMPACT BEARING S 70

Structural bearing for static structural members

### Load deflection curves

The following diagrams show the compression behaviour for different formats when used between concrete surfaces (precast elements).

Thickness 10 mm

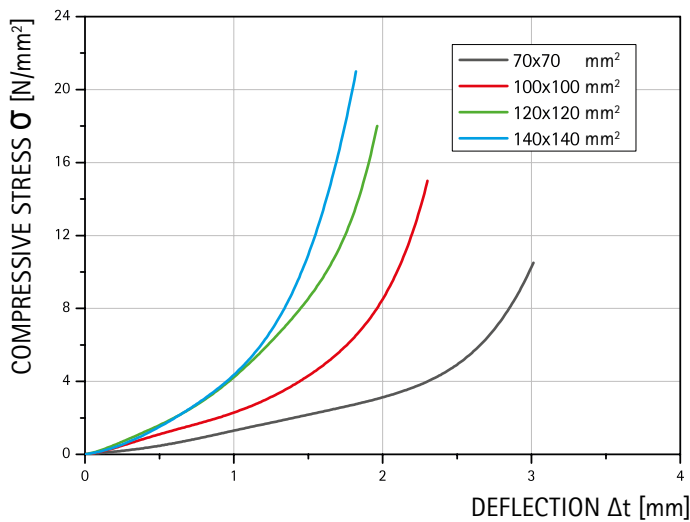

Thickness 15 mm

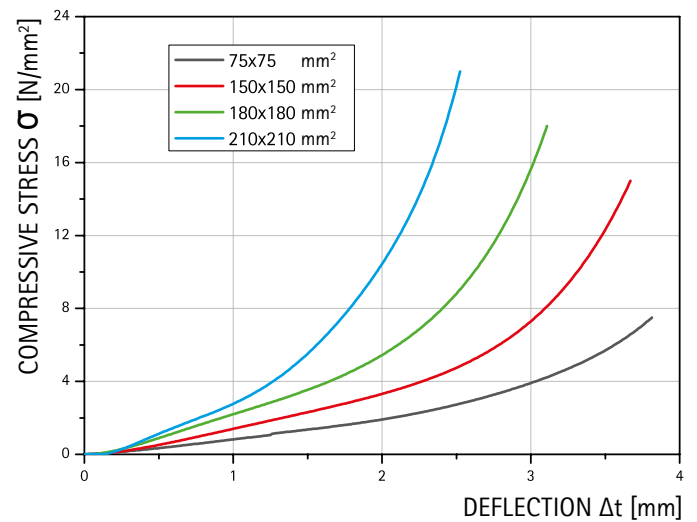

Thickness 20 mm

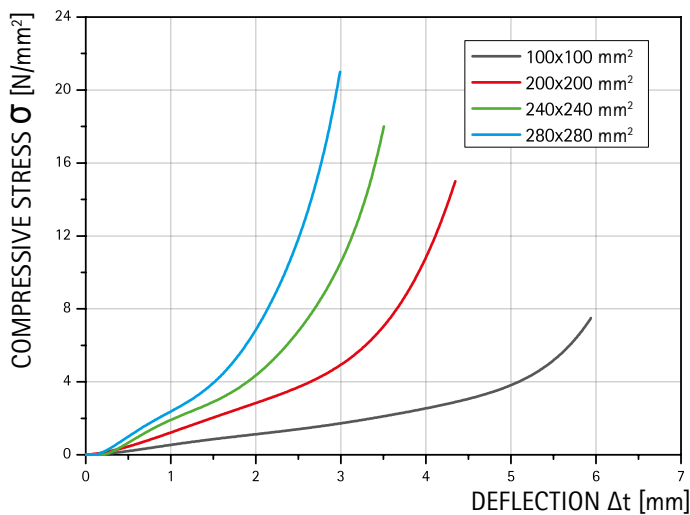

Thickness 10 mm, behaviour at very high  $\sigma$

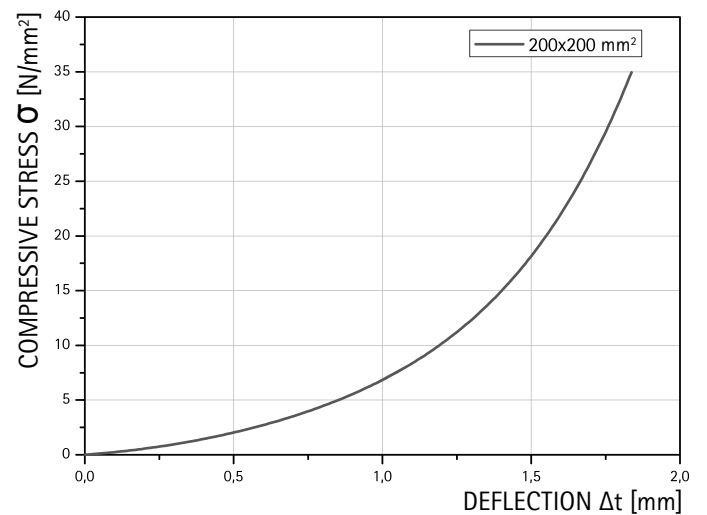

Load deflection curve up to the design value of load capacity acc. to the approval for a bearing of this type with high shape factor.



## COMPACT BEARING S 70

Structural bearing for static structural members

### Design example

Given:  $F_{E,k} = 880 \text{ kN}$  corresponding to  $F_{E,d} = 1,4 \times F_{E,k} = 1232 \text{ kN}^*$ , bearing rotation  $\alpha = 19 \text{ ‰}$ , horizontal deformation  $u = 6,2 \text{ mm}$

Selected dimensions:

$$a_1 = 160 \text{ mm}, b_1 = 370 \text{ mm}, t = 15 \text{ mm}$$

Shape factor:

$$S = \frac{160 \text{ mm} \times 370 \text{ mm}}{2 \times 15 \text{ mm} \times (160 \text{ mm} + 370 \text{ mm})} = 3,7$$

Load capacity:

$$\sigma_{R,d} = 6 \times 3,7 = 22,2 \text{ N/mm}^2 > 21,0 \text{ N/mm}^2$$

$$\rightarrow \sigma_{R,d} = 21 \text{ N/mm}^2$$

$$F_{R,d} = \sigma_{R,d} \times A_E = 21,0 \text{ N/mm}^2 \times 160 \text{ mm} \times 370 \text{ mm} = 1243,2 \text{ kN}$$

$$F_{R,d} \geq F_{E,d} \rightarrow \text{Load capacity of the bearing is sufficient}$$

Bearing distortion from component deflection:  $\alpha = 19 \text{ ‰}$

Additional twisting from obliquity:  $10 \text{ ‰}$

Additional twisting from unevenness:

$$625 \text{ (mm}^* \text{ ‰)} / a \text{ (mm)} = 625 / 160 = 3,9 \text{ ‰}$$

Total rotation to be measured:

$$\alpha = 19 \text{ ‰} + 10 \text{ ‰} + 3,9 \text{ ‰} = 32,9 \text{ ‰}$$

$$\text{max. } \alpha = 450 \text{ ‰} \times t/a = 450 \text{ ‰} \times 15 \text{ mm} / 160 \text{ mm} = 42,2 \text{ ‰} > 40 \text{ ‰}$$

$$\rightarrow \text{zul. } \alpha = 40 \text{ ‰}$$

$$\text{all. } \alpha \geq \alpha \rightarrow \text{Angle of twist for rotation is sufficient}$$

Horizontal deformation of structural members:  $u = 6,2 \text{ mm}$

$$\text{all. } u = 0,6 \times (t-2) = 7,8 \text{ mm}$$

$$\text{all. } u \geq u \rightarrow \text{Shear deformability of the bearing is sufficient}$$

\* Note on partial safety factor: The partial safety factor of a compressive load depends on its type. In case of permanent loads it is e.g. 1.35, in case of variable loads 1.5. Since structural bearings in building construction should only be used under predominantly permanent loads, a factor of approximately 1.4 can be used for the ratio between the total characteristic load and the total design rated load.

## COMPACT BEARING S 70

Structural bearing for static structural members

### Shear stiffness

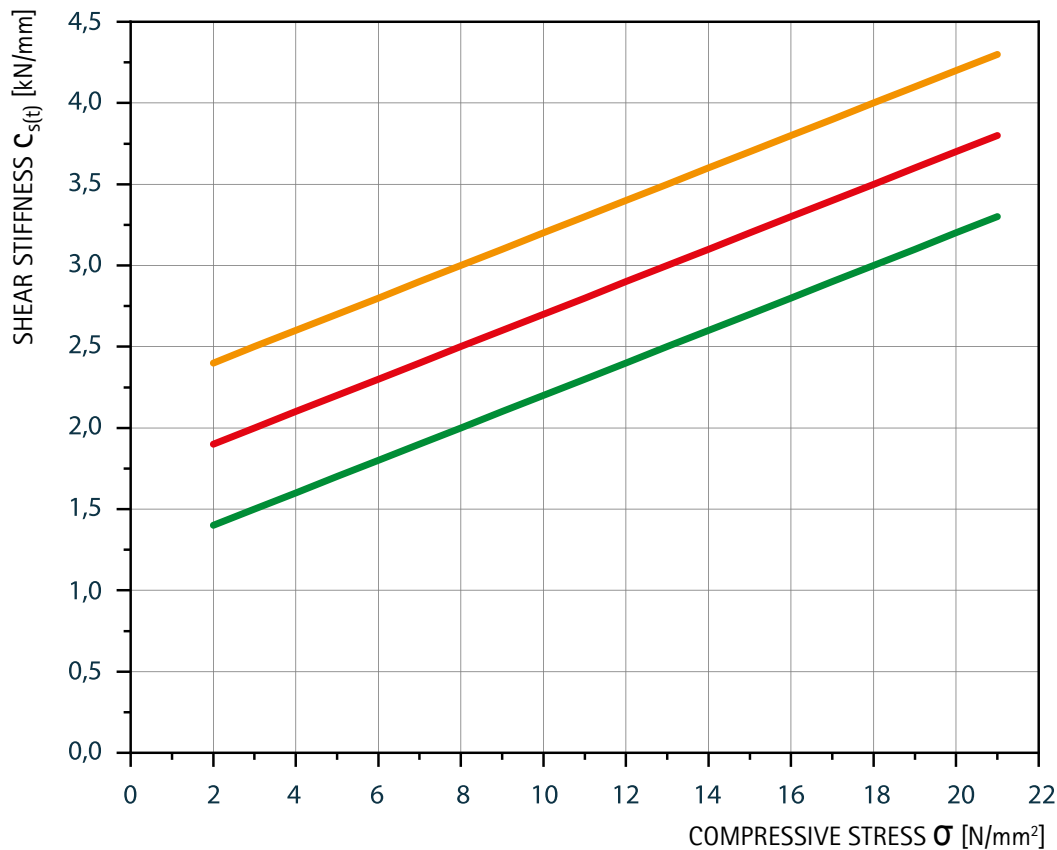

#### SHEAR STIFFNESS CURVE

- 10mm
- 15mm
- 20mm

#### DIAGRAM

For the horizontal shear deformation from uniquely acting horizontal forces, no verification is required, since uniquely slight sliding does not lead to any damaging changes in the structural layout. If the thrust deflection is to be a „pure“ shear deformation, a vertical bearing compressive stress  $\sigma_{E,k}$  of at least 2 N/mm<sup>2</sup> is required.

The contents of this publication are the result of many years of research and experience gained in the application of this technology. All information is given in good faith; it does not represent a guarantee with respect to characteristics and does not exempt the user from testing the suitability of products and from ascertaining that the industrial property rights of third parties are not violated. No liability whatsoever will be accepted for damage – regardless of its nature and its legal basis – arising from advice given in this publication. We reserve the right to make technical modifications in the course of product development.

© Copyright – Calenberg Ingenieure GmbH – 2020

Version 1

28 April 2020

Calenberg Ingenieure GmbH | Am Knübel 2-4 | 31020 Salzhemmendorf | Germany | info@calenberg-ingenieure.de | www.calenberg-ingenieure.de